

VDB30

PARALEL CONNECTED THREE PHASE TRIP CIRCUIT SUPERVISSION RELAY

3 NO + 1 NC CONTACTS THREE COIL TRIP CIRCUIT SUPERVISSION RELAY



APPLICATIONS

- > Whole trip circuit supervision, from Trip contact to common
- > Trip Coils
- > Durability and long lifespan.
- > AC or DC trip circuits, depending the model.
- > Other continuity checks.
- > Triggering of automatic settings change for Backup protections

Substations, Power plants and Industry

- > Critical process automation.
- > Command and Control.
- > Alarm signaling and filtering.

MAIN FEATURES

- > Designed to allow continuous operation even in high temperature ambient, within the whole voltage range..
- > Adapter resistor free.
- > Capable to operate under low duty loads, activate digital inputs, and operate without any load.
- > Tested to comply highest requesting Standards; IEC, EN, IEEE and CE.
- > Sturdy design.
- > High protection degree (IP40), suitable for use in salty and tropical atmospheres.
- > Wide range of auxiliary/monitoring voltage levels (Vdc and Vac).
- > Versatile installation (plug-in relays in a wide range of sockets with different installation configurations).
- > Independent signaling of each coil's failure using NO contacts. NC contact for power source
- > Also supervising trip power source.

FUNCTIONALITY

VDB30 relays are monitoring relays able to supervise if there is a broken path in the route from the trip contact to the common connection in the end side of any of the three trip coils. The supervision is performed through the injection of a very low and calibrated current. If such is possible, the circuit is declared correct, but if the relay cannot inject such current, an alarm condition is declared, and the system can take the proper measures for such situation (trip transfer from the protection and proper settings changes in the backups)

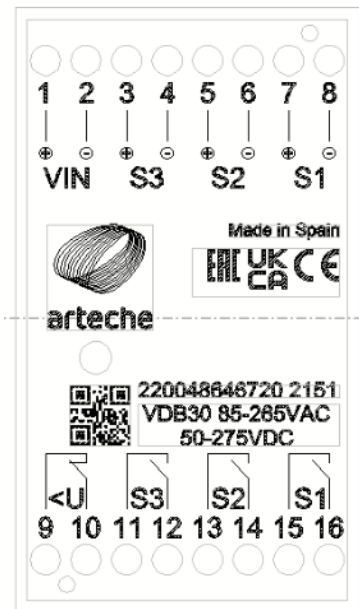

If the lack of continuity loss stays for less than 150 ms, the relay (either model) will stay unsensitive. This is to allow very slow breakers perform the opening/closing maneuver and avoid false alarms which could lead to unnecessary changes of settings in the protection devices, changes of protection zones and sequence coordination.

FUNCTIONAL DIAGRAM

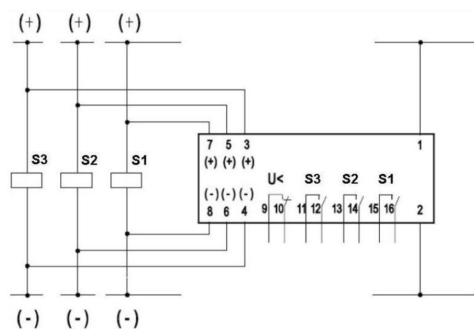

The figure represents the connections of a VDB30 OP that supervises alternatively three trip coils

MARKING

Complies to the most demanding test standards: IEC, EN, IEEE, and bearing the CE mark.

TECHNICAL SPECIFICATIONS

Construction Characteristics

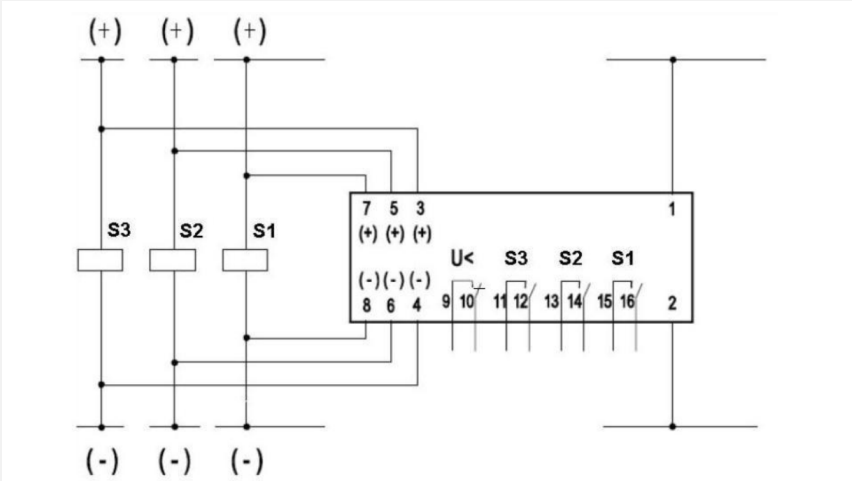
Applications	Trip circuit supervision relay
Contacts	3 NO + 1 NC NO contacts
Connections	
Weight (g)	150 gr
Dimensions (mm)	45 x 75 x 110

Electrical Characteristics

Coil characteristics	Standard voltages	50-375 Vdc 85-265 Vac (50-60 Hz)
	Average consumptions	< 2.5 W
Operating times	Pick-up time	< 150 ms
Contacts	Contact material	AgNi
	Contacts resistance	≤ 30 mΩ
	Continuous current capacity	3 A
	Breaking capacity	100.000 operations
	U _{max} opened contact	250 Vdc / 400 Vac
Dielectric strength independent circuits		4 kV. 50Hz. 1 min
Impulse voltage independent circuits		5 kV. 0,5 J. 1,2/50 μs
Insulation resistance		500 Vdc.; > 100MW

Endurance Characteristics

Mechanical endurance	1*107 operations
----------------------	------------------

Other Standard Compliances			
Emc Immunity	High frequency 1MHz burst disturbance test	IEC 60255-22-1	Common mode: 2,5kV 1MHz and 100 kHz Differential mode: 1kV, 1MHz and 100 kHz
	Electrical Fast transient	EN 61000-4-4	Common mode: 4 kV, 5kHz, 1min Differential mode: 2 kV, 5kHz, 1min
	Surge	EN 61000-4-5	Common mode: 2kV 1,2/50µs. (voltage) 8/20µs. (current) Differential mode: 1kV 1,2/50µs. (voltage) 8/20µs. (current)
	Radiated electromagnetic field	EN 61000-4-3	80-1000MHz, 10V/m, 80% AM (1kHz)
	Digital telephones radiated electromagnetic field	EN 61000-4-3	900 MHz ± 5 MHz, 10 V/m, 50%(200 MHz) 1.89 GHz±10 MHz, 10V/m, 50%(200 MHz)
	Conducted disturbances induced by radio frequency fields	EN 61000-4-6	0.15-80MHz, 10V, 80% AM (1kHz)
	Electrostatic discharges	EN 61000-4-2	Contact ±15 kV Air mode ±15 kV
	Magnetic fields at power frequency	EN 61000-4-8	100 A/m 1min. 1000 A/m 1s.
EMC emissions	Radio disturbance	EN 55011 Class A	Cover: 30Mhz-1GHz Group 1 class A Power supply: 0.15-0.5 MHz, 79dB(µV) (quasi peak) / 66dB(average) 0.5-30 MHz, 73dB(µV) (quasi peak) / 60dB (average)
Environmental Tests	Cold test	EN 60068-2-1 (Test Ab)	- 10°C, 96 hours
	Dry heat test	EN 60068-2-2 (Test Bc)	55°C, 96 hours
	Sudden changes of temperature	EN 60068-2-14 (Test Na)	TA =-25°C; TB = +70°C
Protection Degree		I	IP2X
Operating altitude			<2000 m

BREAKING CAPACITY CURVES

The breaking capacity is a critical parameter on the design and the application of the relay. Its mechanical life could be considerably reduced, depending on the value of the load (especially with heavy duty loads), the number of operations and the environmental conditions in which the relay is operating. (Curves for Op models)

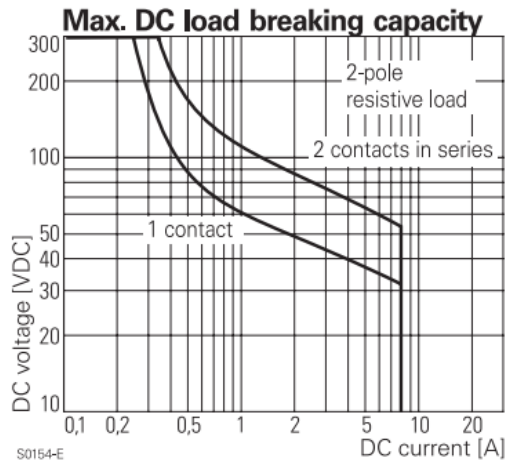
**Resistive load:
L/R = 0 ms**

RELAY DIMENSIONS

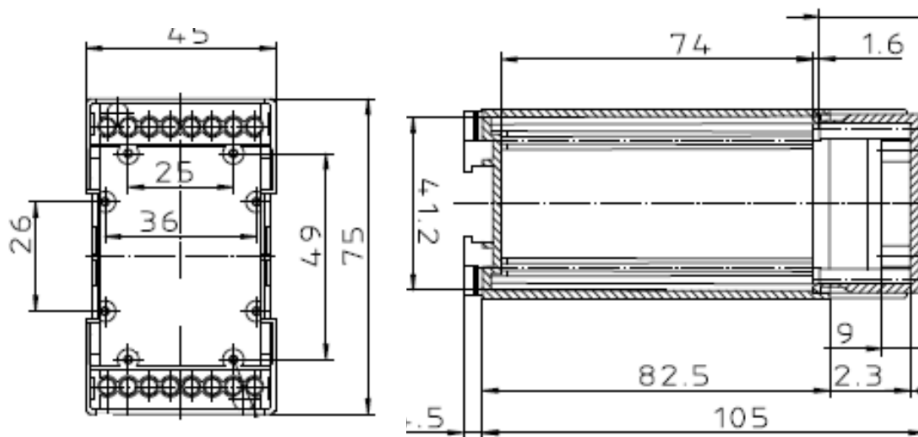

OPTIONS FOR THIS RELAY

This relay must be ordered indication the chosen options

Relay Model	
VDB30	